

L.P. Gas Truck Barrel Tanks

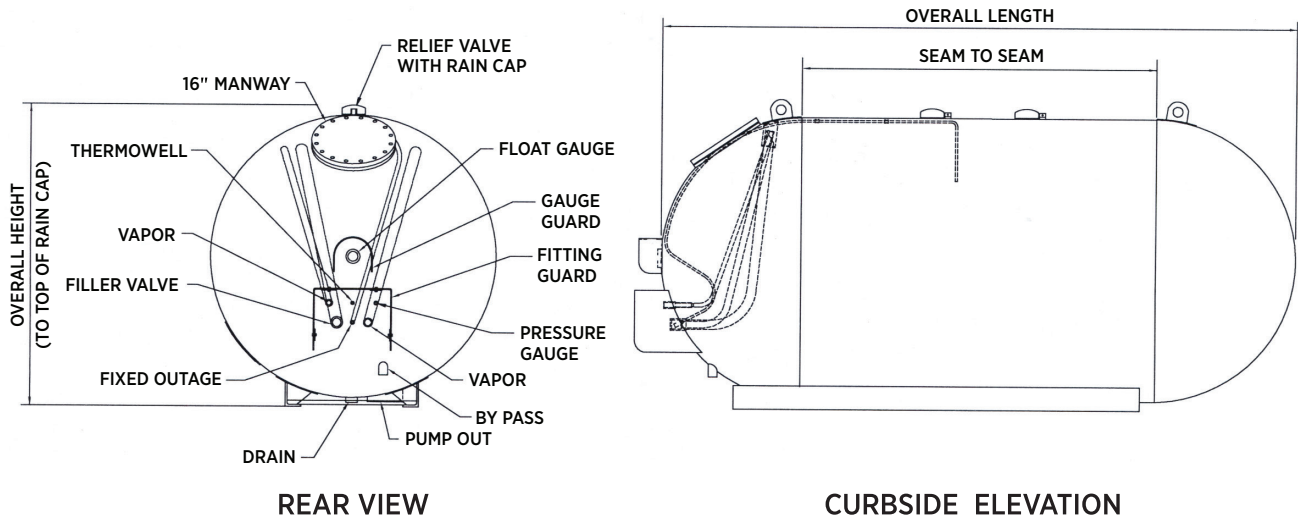

GENERAL SPECIFICATIONS

Conforms to the latest edition, latest revision of the ASME, Section VIII, Division 1 and in full accordance with D.O.T. specification MC-331.

Vessels are externally bladed per SSPC-SP6 and coated with Sherwin-Williams Recoatable Primer.

L.P. GAS TRUCK BARREL DIMENSIONAL INFORMATION

Water Capacity (Gals)	Outside Diameter	Overall Length	Seam to Seam Length	Estimated Weight Lbs
2,000	72.8"	11' - 6 3/8"	5' - 6 5/8"	5,134
2,400	72.8"	13' - 5 1/4"	7' - 6 1/8"	4,759
2,500	72.8"	13' - 11"	7' - 11 7/8"	4,930
2,600	72.8"	14' - 4 5/8"	8' - 5 1/2"	5,420
2,800	72.8"	15' - 4 1/8"	9' - 5"	5,550
3,000	72.8"	16' - 2 1/8"	10' - 3"	5,710
3,200	72.8"	17' - 2 7/16"	11' - 3 5/16"	6,217
2,800	80"	13' - 3 1/8"	6' - 8 7/8"	5,545
3,000	80"	14' - 0 5/8"	7' - 6 3/8"	5,920
3,200	80"	14' - 10 1/8"	8' - 3 7/8"	6,010
3,400	80"	15' - 6 5/8"	9' - 0 3/8"	6,500
3,499	80"	15' - 6 5/8"	9' - 0 3/8"	6,500
5,000	80"	21' - 10 7/8"	15' - 4 5/8"	8,364
5,500	80"	23' - 9 7/16"	17' - 3 3/16"	9,222
4,800	84"	19' - 5 3/4"	12' - 7"	9,614
5,000	84"	20' - 2 11/16"	13' - 4"	8,995
5,500	84"	21' - 10 3/4"	15' - 0"	10,482
6,000	84"	23' - 8 1/4"	16' - 10"	11,748

All vessels dimensions are approximate.

Eng. Update: April 5, 2016



For more information
888.558.8265